

Model X33J PLUS

COMPACT CRAWLERS



Preliminary version



MORE ACCESS

- Market leading working envelope with new boom design providing market leading working outreach.

MORE STABILITY

- Track widening for greater stability during travel.

MORE CAPACITY

- Best-in-class 230 kg unrestricted capacity - take more to the work area.

MORE ECONOMIC

- Minimal emissions and noise pollution.

Standard Features

- 0.70 m x 1.60 m aluminium rear slide bar entry platform (2 people)
- Slide bar rear entry
- Footswitch
- Full proportional control
- Powered platform rotator (180°)
- Removable platform control box
- Full Remote Control of drive and stabilization
- Multi-lingual LCD display on platform console
- Platform console position sensor and lock
- Platform load control system
- Envelope management load sensing system
- Platform designed for ease of removal/changeover
- AC Power Cable to platform
- 6.3 mm Air line to platform
- 12.6 mm Water line to platform
- Engine Guard
- One Button Automatic Stabilizing Outrigger System
- Automatic Stabilization with Variable Outrigger Footprint
- Outrigger pin covers
- Cylinder Rod Protection on Outriggers
- Automatic cut-out when out of level
- 360° non-continuous turntable rotation
- Turntable alignment sensor and gauge
- Emergency descent systems
- Lubrication free bushes
- Electro-hydraulic controls
- 2nd (high) drive speed
- Lifting/Tie down points
- Lanyard anchor points
- Sky Guard
- Quick Stick
- Forklift pockets
- Go Home function

Standard Specifications

Power Source	
• Electric Engine	380V, 50 Hz - 11 kW
• KUBOTA D902	16.1 kW Diesel Engine
• Hydraulic oil tank capacity	80 L
Tracks	
• Standard	2.10 m x 0.23 m x 0.38 m High Profile Non Mark Rubber Tracks

Accessories & Options

- 110V - 230V, 50 Hz single phase power system
- 150Ah/ 76V Electric engine with Lithium battery package
- 2.10 m x 0.23 m x 0.38 m High Profile Black Rubber Tracks
- Special paint colours

Model X33J PLUS

COMPACT CRAWLERS

Performance

• Working Height	32.48 m
• Platform Height	30.48 m
• Horizontal Working Outreach	16.65 m
• Horizontal Outreach	16.00 m
• Up & Over Height	17.20 m
• Platform Capacity	 /230 kg
• Swing (non continuous)	360°
• Jib - overall length	1.3 m
• Jib - range of articulation (+/-)	180° (+85°/- 95°)
• Platform size	0.70 m x 1.60 m
• Platform rotation	180° (+90°/-90°)
A1. Stowed width (with platform)	1.60 m
A2. Stowed width (without platform)	1.19 m
B. Stowed height (on tracks)	1.99 m
C1. Stowed length (on tracks) with Platform	6.50 m
C2. Stowed length (on tracks) without Platform	5.80 m
D 1. Outrigger footprint - total	5.14 m x 4.60 m
D 2. Outrigger footprint - reduced	6.30 m x 3.30 m
E. Track Length	2.10 m
• Operating weight (with engine)	7,616 kg
• Maximum ground bearing pressure (on outriggers)	4.8 kg/cm ²
• Maximum ground bearing pressure (on tracks)	0,8 kg/cm ²
• Maximum drive speed (with standard second speed) Petrol	1.8 km/h
• Gradeability	28.7%
• Maximum operating slope	16°
• Max. Approach / Depart angles	Front 18° / Rear 18°
• Width of Undercarriage (Retracted/Extended)	1.20 m / 1.70m

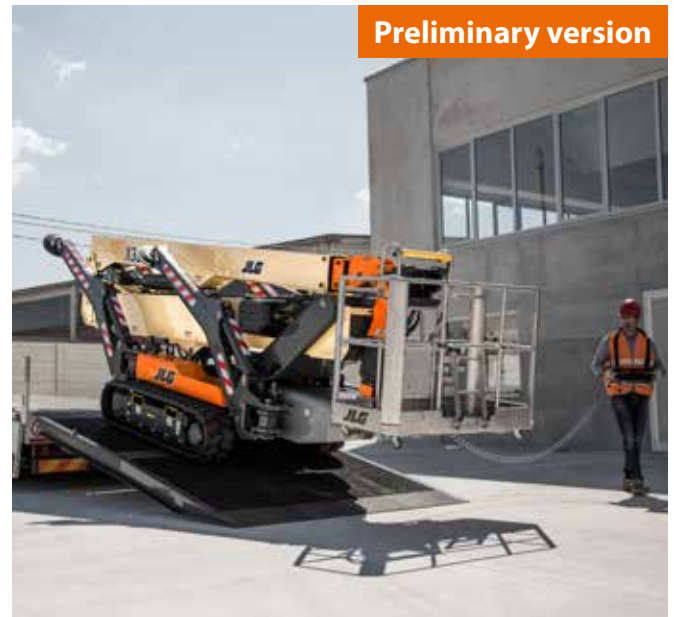

Preliminary version

Note: Certain options or country standards may increase weight and/or dimensions

Reach Diagram

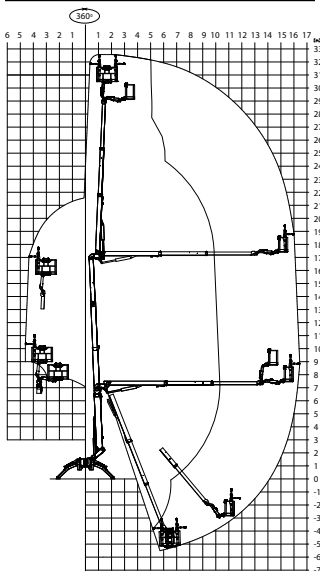

Dimensions

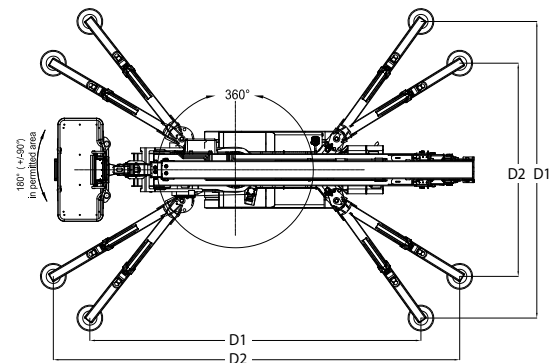
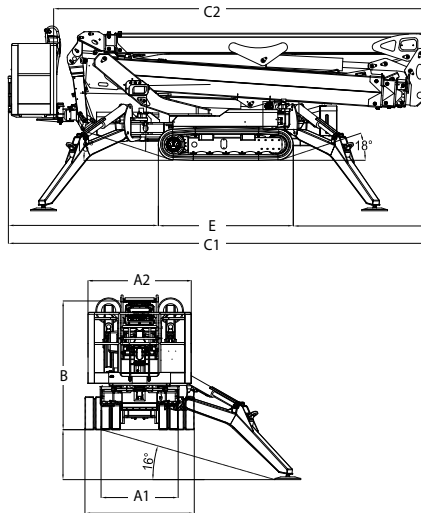

IMPORTANT

JLG is continually researching and developing products and reserves the right to make modifications without prior notice. All data in this document is indicative. Certain options or country standards will increase weight. Specifications may change to meet country standards or with the addition of optional equipment.

Use only JLG approved attachments with proper material handler model/attachment load capacity charts displayed in the operator's cab.

Due to continuous product improvements, JLG Industries reserves the right to make specification and/or equipment changes without prior notification.



JLG EMEA BV

Polaris Avenue 63
2132 JH Hoofddorp
The Netherlands
Phone: +31 (0)23 565 5665
www.jlg.com

An Oshkosh Corporation Company